

CHIRP

AIRMAR delivers CHIRP technology for offshore and freshwater fisherman—at an affordable price!

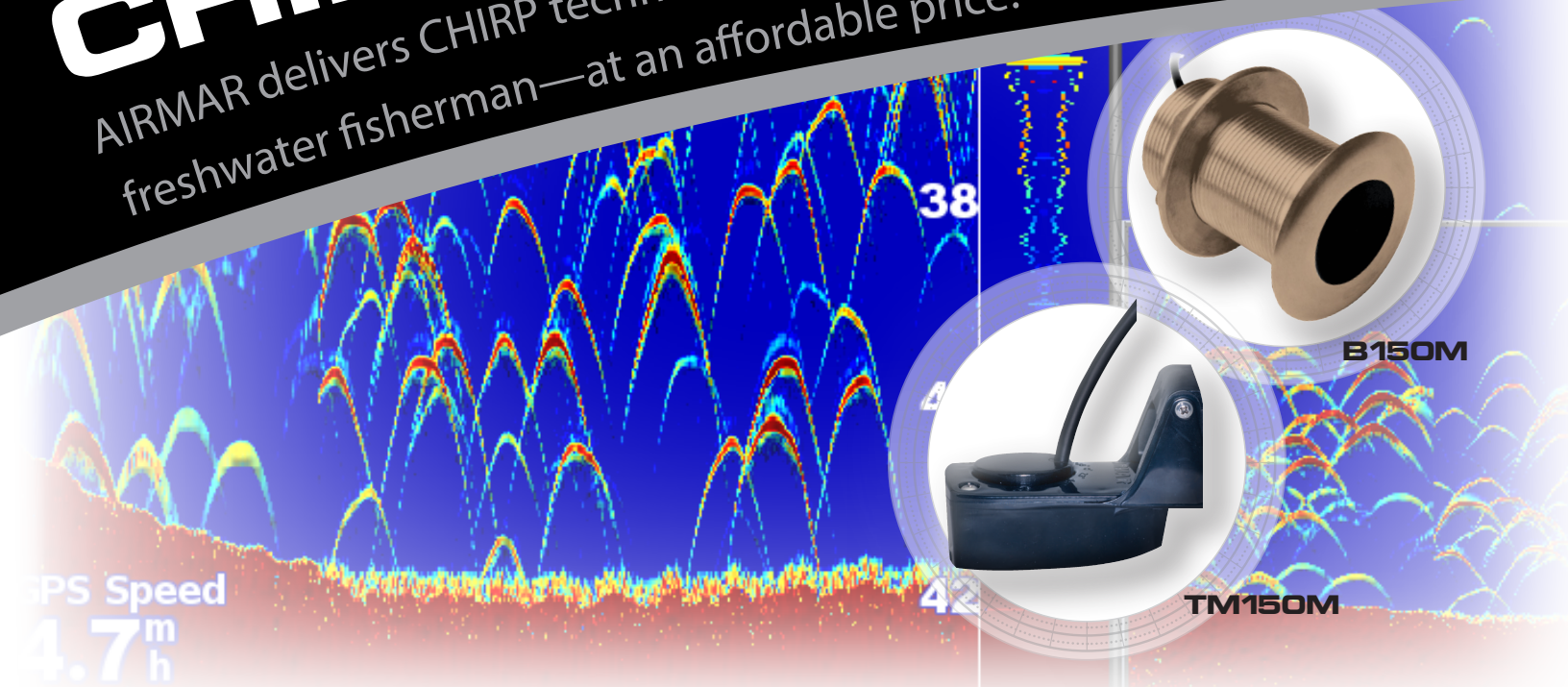

Fish Like the Pros

Introducing TM150M & B150M

As CHIRP continues to redefine recreational fishing, AIRMAR has expanded the lineup of broadband transducers to satisfy the growing demand for this game changing technology. New to the market are the B150M and TM150M, economical **CHIRP** transducers designed for offshore fishing *and* freshwater anglers. Operating at a frequency range of 95-155 kHz, these transducers reveal fish in shallow, murky waters at medium depths (up to 2,500 feet*) along with ultra-clear target resolution.

Designed for smaller boats up to 25', the TM150M is available as a transom-mount transducer or as a trolling motor mount transducer. The B150M is available as a thru-hull transducer with optional tilts of 0°, 12° or 20°.

Stay on top of the fish and ahead of the competition with CHIRP technology!

* Depths vary depending on target strength and sea conditions

FEATURES

- Depth and water temperature sensor
- Ideal for inshore or coastal fishing in shallow to medium depths
- Freshwater anglers will see fish holding close to structures and suspended fish
- Track bottom at higher boat speeds
- More coverage under your boat delivers wider arches and 26° to 17° beamwidths
- Cover the medium frequency range—CHIRPs from 95-155kHz to provide 60 kHz of total bandwidth from one transducer
- Available in plastic transom-mount with stainless steel insert or trolling motor mount installation
 - TM150M trolling motor brackets and hardware
 - TM150M transom bracket and hardware and with a custom transom housing and cover
- Also available as thru-hull installation (B150M)
- Hull Type: Fiberglass, wood or metal
- 1 internal ceramic

Installation Options

TM150M Transom-Mount

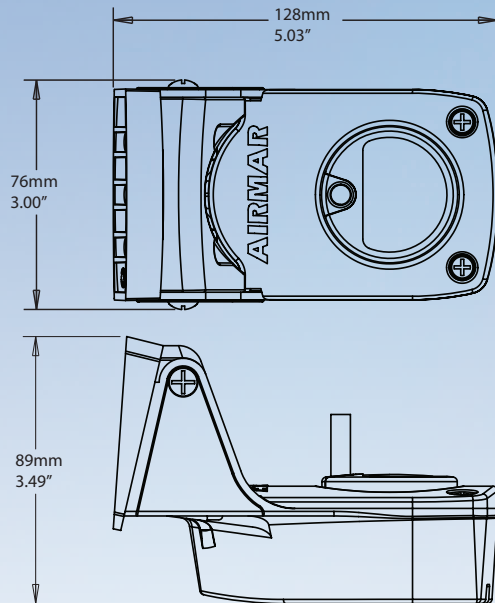

TM150M Trolling Motor Mount

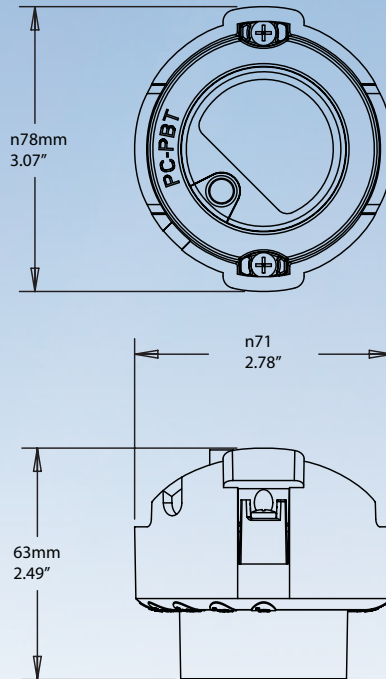

B150M Thru-Hull

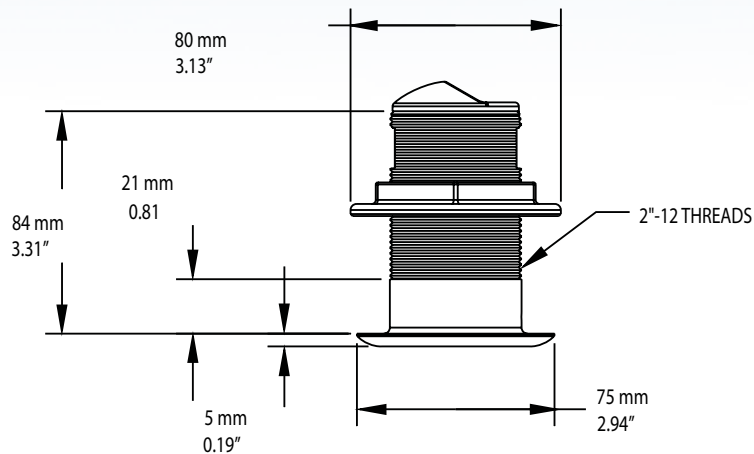

**DEEPER.
BROADER.
CLEARER.**

GAME CHANGING TECHNOLOGY.